

VERSIONER

- Version **N**: utan vridskydd
- Version **V**: med vridskydd
- Version **S**: förstärkt

Förzinkat stål, blåpassiverat **SZ**
Rostfritt stål, slät yta **NB**

KÄNNETECKEN OCH ANVÄNDNING

T-spårsmuttrar GN 50I fäster infästningar och tillbehör i spåren på aluminiumprofiler.

Den fjäderbelastade kulan säkrar T-spårsmuttern mot oönskad glidning i spåret, vilket underlättar installationen.

T-spårsmuttrar av typ N och V kan svängas in i spåret i alla positioner.



GN 50I-N

GN 50I-V

GN 50I-S

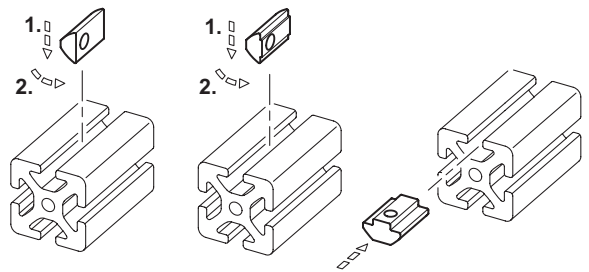

GN 50I-N-SZ
GN 50I-N-NB

urtag vid n = 6mm

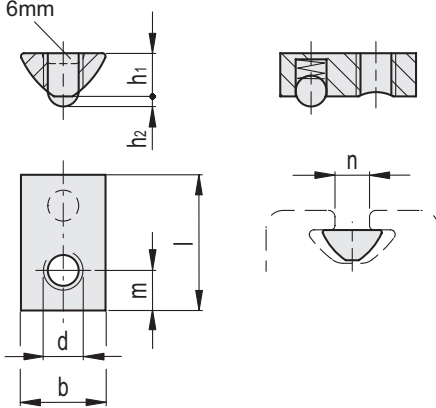

GN 50I-N-SZ

Kod	Benämning	b	n	d	h1	h2	m	Bredd	
GN.72801	GN 50I-5M3-N-SZ	8	5	M3	4	0.8	4	11.5	4
GN.72807	GN 50I-5M4-N-SZ	8	5	M4	4	0.8	4	11.5	3
GN.72813	GN 50I-5M5-N-SZ	8	5	M5	4	0.8	4	11.5	2
GN.72817	GN 50I-6M3-N-SZ	11	6	M3	6	0.9	5	17	6
GN.72821	GN 50I-6M4-N-SZ	11	6	M4	6	0.9	5	17	5
GN.72825	GN 50I-6M5-N-SZ	11	6	M5	6	0.9	5	17	5
GN.72831	GN 50I-6M6-N-SZ	11	6	M6	6	0.9	5	17	4
GN.72841	GN 50I-8M4-N-SZ	14	8	M4	7	1.6	7	23	11
GN.72849	GN 50I-8M5-N-SZ	14	8	M5	7	1.6	7	23	10
GN.72857	GN 50I-8M6-N-SZ	14	8	M6	7	1.6	7	23	9
GN.72865	GN 50I-8M8-N-SZ	14	8	M8	7	1.6	7	23	8

GN 50I-N-NB



Kod	Benämning	b	n	d	h1	h2	m	Bredd	
GN.72805	GN 50I-5M4-N-NB	8	5	M4	4	0.8	4	11.5	3
GN.72811	GN 50I-5M5-N-NB	8	5	M5	4	0.8	4	11.5	2
GN.72839	GN 50I-8M4-N-NB	14	8	M4	7	1.6	5	17	11
GN.72847	GN 50I-8M5-N-NB	14	8	M5	7	1.6	5	17	10
GN.72855	GN 50I-8M6-N-NB	14	8	M6	7	1.6	5	17	9
GN.72863	GN 50I-8M8-N-NB	14	8	M8	7	1.6	5	17	8

Maskincomponenter

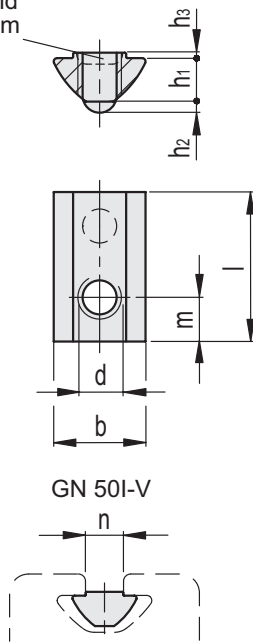
GN 50I-V-SZ
GN 50I-V-NBurtag vid
n = 6mm

GN 50I-V

GN 50I-S-SZ

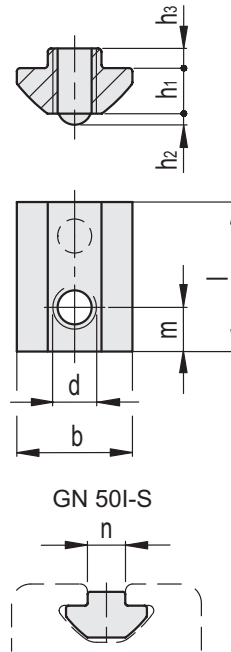

GN 50I-S

GN 50I-V-SZ

Kod	Benämning	b	n	d	h1	h2	h3	m	Bredd	
GN.72803	GN 50I-5M3-V-SZ	8	5	M3	4	0.8	0.7	4	11.5	3
GN.72809	GN 50I-5M4-V-SZ	8	5	M4	4	0.8	0.7	4	11.5	1
GN.72815	GN 50I-5M5-V-SZ	8	5	M5	4	0.8	0.7	4	11.5	6
GN.72819	GN 50I-6M3-V-SZ	11	6	M3	6	0.9	0.5	5	17	5
GN.72823	GN 50I-6M4-V-SZ	11	6	M4	6	0.9	0.5	5	17	4
GN.72829	GN 50I-6M5-V-SZ	11	6	M5	6	0.9	0.5	5	17	4
GN.72835	GN 50I-6M6-V-SZ	11	6	M6	6	0.9	0.5	5	17	3
GN.72837	GN 50I-8M3-V-SZ	14	8	M3	7	1.6	0.8	7	23	15
GN.72845	GN 50I-8M4-V-SZ	14	8	M4	7	1.6	0.8	7	23	14
GN.72853	GN 50I-8M5-V-SZ	14	8	M5	7	1.6	0.8	7	23	13
GN.72861	GN 50I-8M6-V-SZ	14	8	M6	7	1.6	0.8	7	23	12
GN.72869	GN 50I-8M8-V-SZ	14	8	M8	7	1.6	0.8	7	23	10

GN 50I-V-NB



Kod	Benämning	b	n	d	h1	h2	h3	m	Bredd	
GN.72827	GN 50I-6M5-V-NB	11	6	M5	6	0.9	0.5	7	23	4
GN.72833	GN 50I-6M6-V-NB	11	6	M6	6	0.9	0.5	7	23	3

GN 50I-S-SZ

Kod	Benämning	b	n	d	h1	h2	h3	m	Bredd	
GN.72843	GN 50I-8M4-S-SZ	18	8	M4	7	1.6	2.8	7	23	8
GN.72851	GN 50I-8M5-S-SZ	18	8	M5	7	1.6	2.8	7	23	7
GN.72859	GN 50I-8M6-S-SZ	18	8	M6	7	1.6	2.8	7	23	6
GN.72867	GN 50I-8M8-S-SZ	18	8	M8	7	1.6	2.8	7	23	4

